

# ACTA TECNOLOGÍA

electronic journal

ISSN 2453-675X

Volume 4

Issue 1

2018



International Scientific Journal about Technologies

---

**CONTENTS**

**(MARCH 2018)**

**(pages 1-4)**

**MEANS OF USING LOW-POTENTIAL GEOTHERMAL  
ENERGY FOR RECREATIONAL PURPOSES IN THE KOŠICE REGION**

Ján Koščo, Lubomíra Gabániová

**(pages 5-13)**

**INVESTIGATION OF PRESSURE REGULATOR REPLACEMENT BY  
TURBO EXPANDER IN HUNGARIAN GAS TRANSFER STATIONS**

Anna Bella Galyas, László Tihanyi, István Szunyog, László Kis

**(pages 15-19)**

**BIOMEDICAL ENGINEERING AND PROTEOMICS**

Marianna Trebuňová, Jozef Živčák

## MEANS OF USING LOW-POTENTIAL GEOTHERMAL ENERGY FOR RECREATIONAL PURPOSES IN THE KOŠICE REGION

**Ján Koščo**

Institute of Earth Resources, Faculty BERG, Technical University of Košice, Park Komenského 19, 042 00 Košice, Slovakia, jan.kosco@tuke.sk

**Ľubomíra Gabániová**

Institute of Earth Resources, Faculty BERG, Technical University of Košice, Park Komenského 19, 042 00 Košice, Slovakia, lubka.gabaniova@gmail.com

**Keywords:** heat pump, geothermal energy, hydrogeology

**Abstract:** The authors focused on the possibility of using low-potential energy from groundwater by means of heat pumps in the Košice region for recreational purposes as an alternative to geothermal energy obtained from large depths. The article deals with the hydrogeological suitability of the Košice region territory for the use of water-water heat pumps, suitable technical works in the digging of wells as prepare exploitation well and re-injections well, and outputs, while also trying to point out the economics benefits of using low-potential energy from groundwater against to geothermal energy obtained from large depths.

### 1 Introduction

Nowadays, geothermal energy is used for recreational and medical purposes, mainly obtained from geothermal wells reaching a depth of about 2500-3000 m in diameter. This is necessary due to the geothermal gradient, which reaches up to 1°C at 30 m of the drilling depth in most of the territory of the Slovak Republic. For example, some territories in Hungary, where the use of geothermal energy for recreational and medical purposes is already a long tradition, achieve a geothermal gradient of 1°C to 20 m and, in some exceptional cases, 1°C to 15 m, which in practice means that it does not require to be drilled to depths like in our area. This is mainly due to the appropriate geological structure of the area. Of course, it must be water-borne horizons, because water is a medium that ensures the transfer of thermal energy from large depths to the surface. This must be preceded by a rigorous geological survey. All this means huge costs to the exploration itself, as well as to the drilling and replacement of mining and cooling systems, and so on. Under our conditions, the price of 1 km of a borehole in deep boreholes varies between 1300 - 1650 €, which is about 3,000 m deep drilling about 4,5 - 5,0 mil. €. At such a depth it is possible to obtain water at a temperature of about 90-100 °C [1][2].

As a suitable alternative, we can see the possibility of using low-potential geothermal energy from quaternary groundwater, ie from relatively small depths, where there is sufficient yield of these groundwater, even though this groundwater reaches temperatures in the range of 10-12°C. However, even with such low temperatures and sufficient efficiency, it is possible to use thermal water pumps using water-water heat pumps to obtain thermal water at high-temperature heat pumps up to 65°C, which should very well cover the water temperature requirements for

recreational and medical purposes. Basically, the water temperature for these purposes ranges from 26°C to 40°C. Of course, the excess heat obtained can be used for heating purposes as well as heating of domestic water..

The advantage of using heat pumps is also the fact that during the summer months it is not necessary to push the cooled water at the outlet from the heat pump into the intake wells, but it is possible to use this water at a temperature of about 5°C - 7°C to cool the interior spaces, in fact, it will be actually air conditioning. It is worth mentioning that the power of the high-quality pumps is about 35% in relation to the power, which is a huge advantage over conventional gas heating, respectively electricity [3].

### 2 Hydrogeological proportions in the Košice region

The hydrogeological examination of the part of Košice basin is fairly even. Most of the exploration work and evaluation was concentrated here on the groundwater of quaternary collectors and, to a lesser extent, on neogene sediments. The entire studied area is a part of the territory shown on the page 38 Kosice baseline hydrogeological map of scale 1: 200,000 [4] and underground water chemistry maps at the same scale. Textual explanatory notes to the basic hydrogeological map were prepared by Škvarka et al. [5]. The basic data on hydrogeology of quaternary sediments in the assessed area were provided by the work of Struňák [6], Šindler [7], Ondizkova [8] and Frankovič [9]. Later on, Halešová et al. [10,11] discussed this issue. A valuable regional summary of the findings is also provided by Šindler et al. [12] and Halešová with Petrivaldský [13], in which numerous local works are summarized. From a hydraulic point of view, the region of

**MEANS OF USING LOW-POTENTIAL GEOTHERMAL ENERGY FOR RECREATIONAL PURPOSES IN THE KOŠICE REGION**

Ján Koščo; Ľubomíra Gabániová

Košice basin as a whole was evaluated by Jetel and Kaličiak et al. [14].

The area under assessment is the hydrogeological region Q 125 - the Hornád quaternary in which two sub-areas HD-10 and HD-40 are allocated.

From a hydrogeological and structural perspective, the territory consists of a layer of water in the sedimentary collectors of the quaternary.

The uppermost part of the sediments consists of flood plains with a thickness in the range of 0.4 - 2.6 m. From the flow and accumulation of groundwater point of view, the layer of sandy gravel with a thickness of 3.3 to 11.7 m is the most important. The groundwater level at the time of drilling was most often found at a depth of about 2.0 m. A greater number of hydrogeological boreholes are concentrated between Košice and Čaňa, whose maximal values of substantiality [15-17], are from 0.3 to 25.0 l.s<sup>-1</sup>. Some of these wells are used partly as local drinking water sources.

Towards the west, in further distance from Hornád, there is a territory that is part of the HD 20 partial terrain (Hornád terraces). Their lithological composition is more varied than sediment in the valley, mainly due to the more frequent presence of the sand fraction, whether in clay or gravel. The topmost layer of slats does not exceed 1.2 m. The drained collector also includes sandy gravels with an average thickness exceeding 10.0 m. The groundwater level is at greater depths (5.24 - 6.8 m p. T). Earlier exploratory work [10] confirmed the general knowledge of the low usability of groundwater from this environment. The average yield per one well does not exceed 2.0 l.s<sup>-1</sup> [17].

Findings about the possibility of acquiring larger amount of groundwater have also yielded research work [15] aimed at deeper (50 to 150 m) layered gravel and sandy strata of neogen. This is the so- artesian horizons (wells with a positive groundwater level passing through their discharge), in which the yield per one bore is more than 10.0 l.s<sup>-1</sup>.

### 3 Evaluation of means of acquiring groundwater for given purposes

Based on the above-mentioned knowledge of the hydrogeological ratios of the area of interest, it can be stated that the area of interest in considering the use of groundwater for the operation of heat pumps has very good assumptions in this respect.

In the territory of the southern outskirts of Košíc, several boreholes have been carried out to verify the quantity and quality of groundwater, focused on shallow quaternary sediments, as well as on deeper deposited neogene layers. The parameters of the boreholes in question are given in the following Table 1.

In order to ensure the operation of water-water heat pumps with an approximate output of about 1 MW, approximately 35 l.s<sup>-1</sup> will be required from the specified

area. This would be possible to achieve 3-4 farm wells and the same number of wells. In order to provide a water source for the normal operation of the necessary equipment, one water well (well) of about 10 l.s<sup>-1</sup> should be sufficient, but it is also necessary to consider the appropriate reservoir - reservoir of a water source in order to meet the hygienic standards. The location of the individual wells should be consulted with the prospective designer. The distances between the individual wells should range from 40 to 50 m in order to avoid the possible influence of the individual wells in terms of their yield and possibly possible cooling [19].

Table 1 Characteristic data hg boreholes

Borehole Marking	Borehole Depth	Water Temperature	Richness
	h [m]	t[°C]	Q[l.s <sup>-1</sup> ]
VS-9	8,0	12,0	1,42
VS-10	8,7	11,0	7,14
VS-12	10,2	12,0	2,32
VS-13	8,5	11,0	7,60
VS-14	8,5	13,0	7,60
VS-15	8,5	13,0	14,20
VS-15	8,2	12,0	3,30
KAH-6	163,6	16,0	14,47

### 4 Design of suitable heat pump system

Modern electric heat pumps today are an exceptionally ecological option for heat generation. Advanced control systems, efficient compressors as well as sophisticated serial production ensure that modern heat pumps from one piece of electrical current produce up to five parts of heat. Heat pumps can provide heat production monovalently, that is without an additional heat source. Operating costs are significantly lower than conventional heating equipment, which compensates for higher investment over a relatively short period of time. In terms of reliability, unlike in recent years, these devices meet the strictest requirements [20].

For the sake of clarity we will model the use of a cascade-coupled heat pump system. This could be a 3-piece York-Johnson Controls YLCS water-water heat pump of 350 kW (Figure 1), which would mean a maximum output of 1050 kW. Cascaded plugging is more cost-effective, increasing operational reliability of the entire device.



Figure 1 York Johnson Controls: model YLCS of 350 kW

**MEANS OF USING LOW-POTENTIAL GEOTHERMAL ENERGY FOR RECREATIONAL PURPOSES IN THE KOŠICE REGION**

Ján Koščo; Ľubomíra Gabániová

To predict water heating in pool areas, we try to model the need for heat supplied by the heat pump system. Since we do not know exactly how much water will be heated, we will try to process several variants. We expect the average depth in pools of 1m and an area of 500m<sup>2</sup>, 1000m<sup>2</sup> and 1500m<sup>2</sup>. The required temperature in pools where the water will be heated is assumed to be 38°C. It should also be said that these heat pumps can be used at the same time in addition to the heating of water and heating, as well as cooling, that is, the air conditioning used in the summer months. Of course, the combination of solar thermal collectors, which can have a great impact on the reduction of power, especially during the summer months between March and October, will also be a suitable addition to the water heating.

## 5 Determination of the energy balance for pool water heating

Pools in thermal swimming pools are most often filled with water with 27-40°C, which is produced by mixing hot water with cold water in such a proportion as to achieve the required pool water temperature. The filling time depends on the capacity of the water sources. Full water exchange in swimming pools with a flow system takes place within short periods of time (1 – 7 days).

Pools are normally filled at night to avoid interrupting the operation of pools. For this reason, it is preferable to build several smaller pools instead of one large. When replacing water with a non-circulating filler system, the pool swells at the beginning of the season and then complements it, which significantly reduces the demand for both hot and cold water. Water recirculation is considered to be the most perfect way of replacing water in which a certain amount of water is pumped out and recirculated through the filtration plant. The treatment plant must have sufficient capacity resulting from the volume and intensity of the recirculation. The intensity of recirculation is determined by the theoretical time of water retention in the pool and is expressed in hours relative to the average depth of the pool.

The dimensioning of the energy needed to heat the pool water influences to a large extent the swimming pool type (outdoor, indoor), the required parameters of the pool water, the method of limiting the heat losses of swimming pools. The design envisages outdoor, open swimming pools with year-round operation, without hiding pools. The design will be made for pools with a temperature of 36-38 °C and a total pool area of 800, 1000, 1300 and 1500 m<sup>2</sup> and therefore at a water depth of 1m with a volume of 800, 1000, 1300 and 1500 m<sup>3</sup>. Climate and weather conditions of the site are taken into account.

For pool water heating, it is necessary to supply heat for:

- heat loss management by transfer of water level (heating, flow, evaporation),

- heat loss by heat transfer through the swimming pools walls (below water level),
- heating of supplied fresh water (compensation of water loss - spraying, carrying on swimmers' bodies, water for filter cleaning).

Thermal losses due to the pools walls are negligible and therefore are not considered in this proposal. In the energy balance of the pool heat, we also take into account the heat gains that may be the source of direct sunlight.

The determination of the pool's energy requirements is carried out for all months of the year. Inputs are included: Air temperature for individual months, Soil temperature, Air temperature at sunshine, Theoretical sunshine duration, Relative air humidity, Amount of sunlight that falls on m<sup>2</sup> of water surface.

Output is the amount of heat the pool loses during the month and needs to be labeled as Heat requirement to cover losses and the amount of heat needed to heat the incoming clean water indicated as Heat requirement for cold water heating. The overall heat demand is the most important indicator and output of the following tables. The heat requirement per m<sup>2</sup> of surface area is a control indicator. In our conditions it reaches values ranging from 0.4 to 1.4 kW.m<sup>-2</sup>.

The design contemplates heat pumps with an effective power figure of about 3.5, i.e., the heating power of the appliance is 3.5 times higher than the power input required for the heat pump operation. The amount of heat that would be able to supply 3 heat pumps with a heating output of 350 kW is around 756 MWh per month. Calculation example:

$$3 \times 350 \text{ kW} = 1050 \text{ kW} \dots \text{total power of all three heat pump}$$

$$1050 \text{ kW} \times 24 \text{ h} = 25\,200 \text{ kWh} \dots \text{total power of all three heat pump per hour}$$

$$25\,200 \text{ kWh} \times 30 = 756\,000 \text{ kWh} (756 \text{ MWh}) \dots \text{total power of all three heat pump per month}$$

This amount of heat would be supplied by heat pumps in case they would work 24 hours a day with a 100% efficiency. In fact, the heat supply would be somewhat lower.

## 6 Conclusion

At the given input values, when considering the natural conditions in Košice region, water temperature 38 °C, open swimming pool, three heat pumps with heating capacity around 3x350kW, it is possible to count with year-round operation if the surface area of less than 800 m<sup>2</sup> and depth 1m. All of these suggestions are based on assumptions that contribute to the higher overall heat demand to be delivered by heat pumps. Because open pools are assumed, it is wise to consider covering water at a time when pools are out of service, which would greatly reduce losses (up to 50% loss by evaporation). It is appropriate to divide the pool area



**MEANS OF USING LOW-POTENTIAL GEOTHERMAL ENERGY FOR RECREATIONAL PURPOSES IN THE KOŠICE REGION**

Ján Koščo; Ľubomíra Gabániová

into pools with different volumes and water temperatures. Water temperature 36-38°C is over expressed, increases energy demands and also affects the occurrence of microorganisms in water. Each decrease in the water temperature in the pool by several °C contributes to the higher utilization of the intended heat pumps and to the higher economic efficiency of the swimming pool area.

From the individual chapters, it is clear, that the use of low-potential geothermal energy for recreational and medical purposes is possible and economically more advantageous than the use of geothermal energy.

**References**

- [1] HERZ: *Heat pump installation manual HERZ commotherm*, [Online], Available: <http://herz-sk.sk/assets/Uploads/Instalacnaprirucka.pdf> [22 Feb 2017], (Original in Slovak)
- [2] DUNAJSKÝ, E.: *Soil temperature at greater depths*, [Online], Available: [http://www.shmu.sk/File/sms/dunajsky\\_teplota.pdf](http://www.shmu.sk/File/sms/dunajsky_teplota.pdf) [15 March 2017], (Original in Slovak)
- [3] SZCHKT: *Certification of heat pump installers within the EU.CERT.HP*, Rovinka: SZCHKT, pp.230, manuscript, 2006. (Original in Slovak)
- [4] ŠKVARKA, L. (Ed.): *Basic hydrogeological map of CSSR 1: 200 000*, sheet 38 Michalovce. GÚDŠ Bratislava & Slovak Cartography Bratislava. Map sheet 1985.
- [5] ŠKVARKA, L. et al.: *Basic hydrogeological map of CSSR 1: 200 000*, sheet 38 Michalovce. Manuscript - Archive of Geofond Union ŠGÚDŠ Bratislava, 314 p., arch.numb. 38766. 1976.
- [6] STRUŇÁK et al.: *Hydrological survey of the Hornád river under the confinement with Torysa*. [Online], Available: <http://www.archaeol.freeuk.com/EHPostionStatement.htm> [7 May 2018], 1961. (Original in Slovak)
- [7] ŠINDLER et al.: *Hydrogeological survey of the river Torysa*, [Online], Available: <http://www.geoarchiv.tuke.sk/rok.php?action=view&kriterium=1962> [7 May 2018], 1962. (Original in Slovak)
- [8] ONDŽÍKOVÁ, Ľ.: *Assessment of hydrogeological exploration – actions "Hydrogeological survey of the lower stream of Hornád"*. Manuskript - archive ŠGÚDŠ, Bratislava 1963.
- [9] FRANKOVIČ et al.: *Hydrogeological survey of the Hornád river in the section Gýňov - state border II, detailed survey*. [Online], Available: <http://www.geoarchiv.tuke.sk/rok.php?action=view&kriterium=1965> [7 May 2018], 1965. (Original in Slovak)
- [10] HALEŠOVÁ et al.: *Neogen and Quaternary of the eastern part of Košice basin, hg. study* [Online], Available: <http://www.geoarchiv.tuke.sk/rok.php?action=view&kriterium=1984> [7 May 2018], 1984. (Original in Slovak)
- [11] HALEŠOVÁ et al.: *Neogen and Quaternary basin of the Košice basin in Bodvy basin - hg. district NQ 138* [Online], Available: <http://www.geoarchiv.tuke.sk/rok.php?action=view&kriterium=1985> [7 May 2018], 1985. (Original in Slovak)
- [12] ŠINDLER et al.: *Košice - preparatory study on hg. exploration and use of groundwater* [Online], Available: <http://www.geoarchiv.tuke.sk/rok.php?action=view&kriterium=1988> [7 May 2018], 1988. (Original in Slovak)
- [13] PETRIVALDSKÝ et al.: *Košice - Airport, hv. groundwater assessment, hydrogeological assessment* [Online], Available: <http://www.geoarchiv.tuke.sk/rok.php?action=view&kriterium=1990> [7 May 2018], 1990. (Original in Slovak)
- [14] KALIČIAK, M., et al.: *Geological map of Slanské vrchy and Košice basin - southern part, 1: 50,000*. Geological Service of the Slovak Republic Bratislava. 1996.
- [15] FRANKOVIČ et al.: *Košice - Sever, adding water resources, search hg. research* [Online], Available: <http://www.geoarchiv.tuke.sk/rok.php?action=view&kriterium=1977> [7 May 2018], 1977. (Original in Slovak)
- [16] PETRIVALDSKÝ et al.: *Golden Mine - Hydrochemical evaluation of groundwater and surface water, preliminary report, preliminary survey* [Online], Available: <http://www.geoarchiv.tuke.sk/rok.php?action=view&kriterium=1982> [7 May 2018], 1982. (Original in Slovak)
- [17] KOŠČO, J., KUDELAS, D., TOMETZ, L., DOMARACKÝ, D.: *Exploring the means of using low-potential geothermal energy at Košice - Krásna for recreational purposes*, TU, pp. 33, 2011.
- [18] PETRIVALDSKÝ et al.: *Hraničná pri Hornáde - search hydrogeological survey* [Online], Available: <http://www.geoarchiv.tuke.sk/rok.php?action=view&kriterium=1982> [7 May 2018], 1982. (Original in Slovak)
- [19] RAPANT, S. - VRANA, K. - BODIŠ, D. a kol.: *Atlas of groundwater* [Online], Available: <http://mapserver.geology.sk/atlaspv>, [12 Apr 2017], 2011, (Original in Slovak)
- [20] KARLÍK, R.: *Heat pump for your house*. Praha, Grada Publishing, a.s., 2009.

**Review process**

Single-blind peer review process.

**INVESTIGATION OF PRESSURE REGULATOR REPLACEMENT BY TURBO EXPANDER IN HUNGARIAN GAS TRANSFER STATIONS**

Anna Bella Galyas; László Tihanyi; István Szunyog; László Kis

doi:10.22306/atec.v4i1.33

Received: 25 Mar. 2018

Accepted: 30 Mar. 2018

**INVESTIGATION OF PRESSURE REGULATOR REPLACEMENT BY TURBO EXPANDER IN HUNGARIAN GAS TRANSFER STATIONS****Anna Bella Galyas**

University of Miskolc, Miskolc – Egyetemváros, Miskolc, Hungary, gazgab@uni-miskolc.hu

**László Tihanyi**

University of Miskolc, Miskolc – Egyetemváros, Miskolc, Hungary, tihanyiil@kfgi.uni-miskolc.hu

**István Szunyog**

University of Miskolc, Miskolc – Egyetemváros, Miskolc, Hungary, szunyogi@kfgi.uni-miskolc.hu

**László Kis**

University of Miskolc, Miskolc – Egyetemváros, Miskolc, Hungary, oljkisl@uni-miskolc.hu

**Keywords:** turbo expander, transmission system, energy efficiency, natural gas, power production**Abstract:** The "Strategy for a stable and adaptable energy union and a forward-looking climate policy", developed by the European Commission and endorsed in 2015, states that "... our goal is to make the energy union a long-term sustainable carbon-free and climate-friendly economy" [1]. As a result of the above, we have been looking for the conditions and the technical solutions under which the necessary pressure regulation at the gas transfer stations can use the pressure energy economically.

## 1 Introduction

One of the tasks of the gas transfer stations is that the pressure regulators installed therein have to reduce the pressure of the natural gas from the high pressure transmission system and to supply them to the consumers or to the gas distribution system at the pressure defined in the "Business and Commercial Code of the Hungarian Natural Gas System" (hereinafter referred to as ÜKSZ). During the process, there is a high level of energy loss that is lost without recovery in conventional pressure regulating systems. It has been known for a long time that natural gas pressure can be utilized using a turbo expander and an attached electric generator. The electricity thus produced can, among other things, be used to reduce the energy demand of the gas transfer stations or to be supplied into the electric network.

In this paper, the energy requirement by conventional pressure regulators and turbo expanders are presented along with the amount of energy produced by the latter. The Aspen HYSYS technological design software used in the oil and gas industry was used for carrying out the required investigations.

## 2 Infrastructure of the Gas Supply System in Hungary

Natural gas plays a significant role in the energy supply of Hungary, and its delivery to users is carried out in the natural gas supply system. All mentioned pressures are overpressures.

The natural gas transmission system operated by the FGSZ LTD. consists of supply points "0", compressor stations, gas hubs, metering stations, high pressure pipelines and gas transfer stations that are directly

connected to regional gas supply companies and to industrial customers. The natural gas transmission system is the central element of pipeline energy supply that delivers natural gas from the production fields, from imports or from underground gas storages to consumer districts. In addition, it ensures the technical conditions for accurate measurement and settlement in the country's legislation. The natural gas pipelines operate in a pressure range of 25-100 bar, allowing them to safely and economically transport natural gas [2]. The Hungarian natural gas transmission system has a typical diameter of 100 to 1400 mm and an operating pressure of 25 to 75 bar. The endpoint of the high-pressure gas transmission system is the gas transfer station to which a smaller distribution network is connected. At these border points, controlled gas transmission to the connected system operators and direct industrial users is continuously maintained. Distribution system operators are supplying natural gas to nearly 3.5 million consumers via gas distribution networks operating at less than 25 bar. The Hungarian national regulations defines a high-medium ( $25 > p > 10$  bar), medium ( $10 > p > 0.1$  bar) and low ( $p < 0.1$  bar) pressure range as the operating range of gas distribution systems. In Hungary, apart from some exceptions, to the endpoints of the gas transmission systems 6 bar gas distribution systems are connected [3].

At the gas transfer station, which is the connection between the gas transmission system and gas distribution system, the regulations on the physical parameters of natural gas have to satisfy the provisions of ÜKSZ. According to the regulations, the gas temperature measured at the exit points has to be above 0 °C. For the nominal exit pressure value, a range of 3 to 15 bar is specified for new

**INVESTIGATION OF PRESSURE REGULATOR REPLACEMENT BY TURBO EXPANDER IN HUNGARIAN GAS TRANSFER STATIONS**

Anna Bella Galyas; László Tihanyi; István Szunyog; László Kis

exit points, for existing exit points the pressure can be adjusted according to the system suitability test [4]. In the

### 3 Presentation of the Gas Transfer Station

The gas transfer station is the endpoint of the natural gas transmission system, a technological station connected to the end of a transmission line or a branch line therefrom, whereby the delivered gas is transmitted to the industrial consumer or to the gas supply system. At present, there are nearly 400 gas transfer stations on the domestic gas transmission system, with the main tasks of filtration, gas heating, pressure regulation, pressure assurance, gas quantity measurement and proper odor setting [2].

The stations have two full, uniform, disconnectable, parallel pressure regulating branches; their default configuration is filter, heat exchanger, shut-in valve, monitor regulator, active regulator, low capacity (defect gas) relief valve with measurement device. The most important element of the installation is the pressure regulator coupled with the shut-in valve. The pressure regulator maintains the flow from the gas transport system to a lower pressure line, while the pressure of the lower pressure side is kept constant even at varying inlet pressure. The currently commercially available pressure regulators are pneumatic equipment whose working fluid is natural gas. The shut-in valve is the ultimate tool for limiting overpressure. The filter unit is in front of the pressure regulator, the odor unit is located after the pressure regulator. On the low pressure side of the station there is the measuring unit and the spare odor unit. Preheating natural gas is necessary to avoid hydrate formation when the pressure drop exceeds 14 bar. The natural gas is heated

majority of the gas transfer stations, the transfer of the natural gas supplied is 6 bar for the distribution system.

by a counter-current tubular heat exchanger to which the hot water is provided by gas boilers in separate premises. In this system, the heat input is directly in front of the pressure regulator, so the heat loss is minimal and the gas flow temperature can be precisely controlled. Shut-in valves are pressure controlled closing elements that can be used to disable gas flow immediately. The shut-in valve is installed in front of the pressure regulator but is controlled by the pressure after the regulator. Controlled pressure acts through the impulse line with small diameter to the pneumatic control unit which changes the flow cross section by changing the pressure of the working medium. [2].

## 4 Placing the turbo expander in pressure reduction station

### 4.1 Presentation of turbo expander

A turbo expander, also known as expansion turbine, is a radial or axial turbine through which energy can be produced using the expansion of high pressure gas. Both the radial and axial turbines are used in practice, although the use of the former is more common. The turbo expander and the generator are connected to each other on a common axis.

The so-called cold energy extracted from natural gas is transformed into mechanical energy that drives the shaft. The turbo expander is placed on the bypass line at the gas transfer station, along with a traditional pressure regulator, as shown in Figure 1.

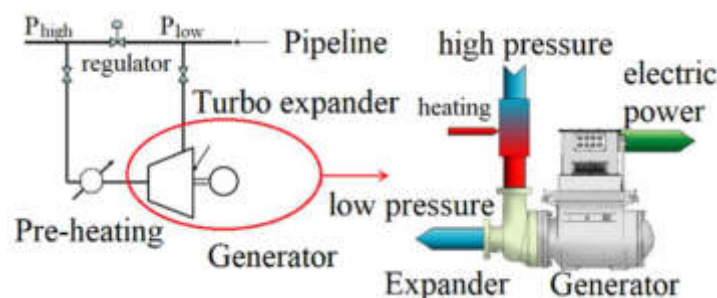

Figure 1 Schematic construction of gas transfer station with turbo expander [5, 6]

Figure 1 shows the placement and schematic operation of a turbo-expander unit. The high pressure gas needs preheating due to the high temperature drop due to the isentropic expansion. The gas enters the expander where it expands. Most of the cold energy extracted from this process is transformed into mechanical energy. The generator converts mechanical energy into electrical energy.

### 4.2 Different methods of pressure regulation

At the gas transfer station, the pressure of natural gas is reduced by pressure control valves to the desired value. In

this case, it is an isenthalpic process; the enthalpy of the gas stream is identical on both sides of the valve. This throttle condition is thermodynamically irreversible. As a result of the isenthalpic throttle, the gas temperature drops due to the Joule–Thompson effect.

Contrary to the foregoing, the process using a turbo expander is isentropic, meaning that the entropy of the system is constant. In the latter case, the enthalpy change can be used for work.

The turbo expander is essentially an inverted compressor. The arrangement is capable of utilizing the



**INVESTIGATION OF PRESSURE REGULATOR REPLACEMENT BY TURBO EXPANDER IN HUNGARIAN GAS TRANSFER STATIONS**

Anna Bella Galyas; László Tihanyi; István Szunyog; László Kis

internal energy of the natural gas stream during the expansion of natural gas.

The mechanical energy extracted from natural gas results in a higher thermal drop during the isentropic process than in the case of isenthalpic throttle at the same pressure ratio. The difference between the two processes is illustrated in Figure 2.

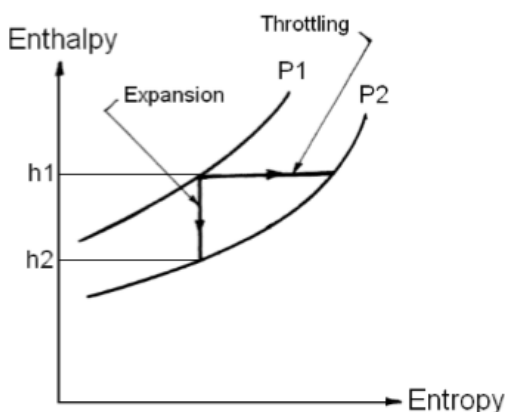

Figure 2 The difference between pressure reduction processes [7]

In the case of throttling or working expansion, the gas outlet temperature also depends on the composition of natural gas. In both cases, the high pressure gas requires preheating, but its rate is much higher when using a turbo expander than using a pressure regulator.

According to the literature, more and more publications have recently been published investigating energy usage of the gas stream at gas transfer stations [5] ... [15]. The

reason for this is probably that today there are already available turbo expanders that are widely used in gas processing and gas liquefaction technologies as well as waste heat utilization cycles. In connection with the applications, not the feasibility but the economy became the focus of attention. For gas transfer stations, economics is fundamentally influenced by the fact that the use of natural gas and, as a result, the amount of the regulated gas significantly fluctuates seasonally.

**5 Investigations using simulation**

**5.1 Introduction of model used in investigation**

The results obtained from the simulation of created models using Aspen HYSYS simulation software that is used in the petroleum and gas industry are presented and evaluated in this chapter. For the comparability of the tests, we used a model that simultaneously models the state change using pressure regulator and turbo expander system with various gas flows, input pressures and input temperatures. In the model, the gas flow is distributed evenly. Thus, the calculations were performed simultaneously for both branches. The purpose of these model examinations was to determine whether the natural gas pressure energy can be utilized with the help of a turbo expander for electricity generation. The role of the gas transfer station cannot change even using a new technological solution. At gas transfer stations, natural gas shall be regulated from the current pressure and temperature values to the 6 bar discharge pressure set in ÜKSZ and the temperature of the natural gas should not be less than 0 °C after regulation.

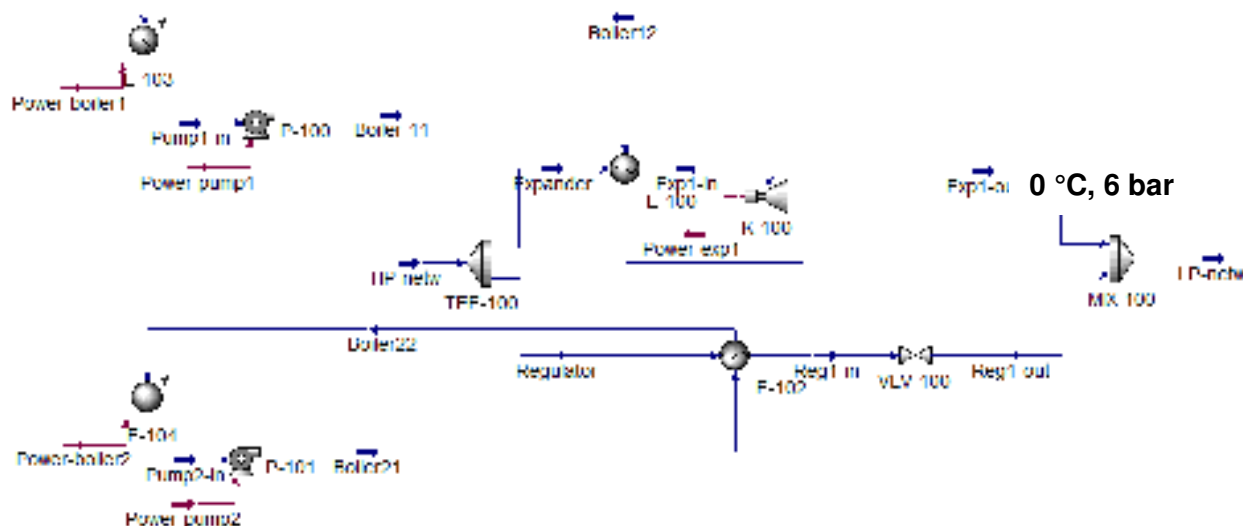

Figure 3 Aspen HYSYS model for a gas transfer station equipped with a turbo expander (upper) and a pressure regulator (lower)

In Figure 3 a branch with a turbo expander unit (top) and a branch with a conventional pressure regulator (bottom) is presented. The gas flow is the same in both

branches as well as the inlet pressure and temperature at the HP-netw node and the outlet pressure and temperature in the LP-netw node.

**INVESTIGATION OF PRESSURE REGULATOR REPLACEMENT BY TURBO EXPANDER IN HUNGARIAN GAS TRANSFER STATIONS**

Anna Bella Galyas; László Tihanyi; István Szunyog; László Kis

It must be taken into account that during the winter season the amount of natural gas flowing through the gas transfer station will increase considerably and that the soil temperature will be lower than the summer temperature. Because of the above, the gas must be heated before the pressure regulation. This is done by a gas heating system in which a gas-fired boiler heats the water used as the intermediate medium to such an extent that the temperature at the output side of the pressure regulating element is at a given value. In this auxiliary system, the energy required to circulate the water is provided by an electric motor driven pump.

The pump can only operate with 100% fluid phase, so the pressure of the heating circuit must be chosen so that the heating medium remains in liquid state from the discharge side of the pump to the suction side of the pump. In some cases, especially in the case of gas transfer stations – not too far from the outlet point of the compressor stations – there may be a situation in which, regulating at 6 bar at the gas transfer station, the output temperature of 0 °C can only be obtained if the gas is heated up to 100 °C before the pressure regulator, occasionally exceeding this temperature. Especially when using a turbo expander, this may occur.

## 5.2 Analysis of Turbo Expander and Pressure Regulating Unit

During the tests, gas transfer stations with different capacities were tested. In order to investigate the widest range of operations, three different gas transfer station groups were defined, depending on the gas flow rate and

the arrival pressure. The tests, assuming a constant typical composition of natural gas were performed at different inlet natural gas temperatures of 4 °C, 8 °C and 12 °C.

### 5.2.1 Examination of High Capacity, High-Pressure Gas Transfer Station

High-capacity gas transfer stations were considered that are close to the compressor station and for which both the arriving pressure and the gas flow were high.

The test range of the flow rate was between 10,000 and 22,000 m<sup>3</sup>/h using 4,000 m<sup>3</sup>/h step size. A significant proportion of domestic gas transfer stations are included in this group regarding the maximum capacity. The inlet pressure was characterized by a pressure range of 45 to 55 bar. The calculation results for this category are shown in Table 1 and 2. In the tables, the energy data calculated for the natural gas pre-heating circuit, the gas heating boiler and the pump are shown. The operation of these technological units is associated with their energy usage, which should be indicated in the energy balance. In the tables, the total power requirement is shown for both cases. The value shown in the table with dark gray is the amount of energy produced by the turbo expander unit.

It is important to emphasize that the energy demand of a built-in gas heating boiler as part of the preheating circuit is covered by using natural gas for technological purposes and only the electricity needed to operate the pumps must be purchased from an external service provider.

Table 1 shows the results of a high-capacity gas transfer station with an inlet pressure of 45 bar.

Table 1 The amount of produced energy at 45 bar inlet pressure

p= 45 bar	Unit	Q=10,000 m <sup>3</sup> /h		Q=14,000 m <sup>3</sup> /h		Q=18,000 m <sup>3</sup> /h		Q=22,000 m <sup>3</sup> /h	
		Exp.	Valve	Exp.	Valve	Exp.	Valve	Exp.	Valve
<b>T= 4 °C</b>									
Heating power	kW	519,0	87,0	727,0	121,0	935,0	156,0	1143,0	191,0
Pump power	kW	0,48	0,15	0,54	0,15	0,57	0,19	0,70	0,19
Total power requirement	kW	519,48	87,15	727,54	121,15	935,57	156,19	1143,70	191,19
Produced energy	kW	433,0	0,0	607,0	0,0	780,0	0,0	953,0	0,0
<b>T= 8 °C</b>									
Heating power	kW	499,0	66,0	699,0	93,0	898,0	120,0	1099,0	146,0
Pump power	kW	0,49	0,15	0,53	0,15	0,58	0,19	0,70	0,19
Total power requirement	kW	499,49	66,15	699,53	93,15	898,58	120,19	1099,70	146,19
Produced energy	kW	433,0	0,0	607,0	0,0	780,0	0,0	953,0	0,0
<b>T= 12 °C</b>									
Heating power	kW	479,0	46,0	670,0	93,0	862,0	84,0	1054,0	102,0
Pump power	kW	0,49	0,15	0,53	0,15	0,57	0,19	0,70	0,19
Total power requirement	kW	479,49	46,15	670,53	93,15	862,57	84,19	1054,70	102,19
Produced energy	kW	433,0	0,0	607,0	0,0	780,0	0,0	953,0	0,0

It can be seen that the amount of energy to be consumed is increased proportionally with the growth of the delivery task. While at 10,000 m<sup>3</sup>/h, 433 kW of energy can be extracted with a turbo expander, 953 kW can be produced

at 22,000 m<sup>3</sup>/h. Energy demand for preheating gas is also increasing proportionally. The energy demand of the gas boiler is almost always at least 99% of the invested energy requirement, but this is technological use of natural gas

**INVESTIGATION OF PRESSURE REGULATOR REPLACEMENT BY TURBO EXPANDER IN HUNGARIAN GAS TRANSFER STATIONS**

Anna Bella Galyas; László Tihanyi; István Szunyog; László Kis

within the gas transmission system, which can be accounted for by a system operator at a significantly lower price. The required pump power does not exceed 1 kW. For the gas flow of 10,000 m<sup>3</sup>/h, nearly 520 kW of heat output is required for the theoretical performance of 433 kW, thus 87 kW own energy investment is required. In the case of the pressure regulator there is no power generation, 87 kW of heat is required for the preheating of the gas to maintain the prescribed 0 °C and 6 bar.

With pressure regulation using a turbo expander, the power requirement for 22,000 m<sup>3</sup>/h is 1,143 kW due to natural gas preheating and 953 kW mechanical or slightly lower electrical output is achievable. When the temperature dependence is investigated using the energy balance of the gas transfer stations, it is apparent that as the temperature

of the natural gas from the supply line increases, the energy demand of the preheating is reduced. It can also be seen that in case of a given transport capacity, the increase of the gas temperature does not affect the energy produced by the turbo expander. At the same time, if the gas temperature increases, the boiler's power requirement is reduced. While in the case of 10,000 m<sup>3</sup>/h, at 4 °C, nearly 520 kW power demand was required during the preheating of gas, in the case of 12 °C this value is reduced to 480 kW. However, in both cases 433 kW can be gained with a turbo expander. While in the former case there is a difference of 87 kW between the heating circuit and the output power, in the latter case it is only 47 kW. Table 2 summarizes the calculation results for a 55 bar inlet pressure.

Table 2 The amount of produced energy at 55 bar inlet pressure

p= 55 bar	Unit	Q=10,000 m <sup>3</sup> /h		Q=14,000 m <sup>3</sup> /h		Q=18,000 m <sup>3</sup> /h		Q=22,000 m <sup>3</sup> /h	
		Exp.	Valve	Exp.	Valve	Exp.	Valve	Exp.	Valve
<b>T= 4 °C</b>									
Heating power	kW	595,0	114,0	832,0	160,0	1070,0	206,0	1308,0	252,0
Pump power	kW	0,53	0,15	0,62	0,19	0,71	0,26	0,80	0,30
Total power requirement	kW	595,53	114,15	832,62	160,19	1070,71	206,26	1308,80	252,30
Produced energy	kW	481,0	0,0	673,0	0,0	866,0	0,0	1059,0	0,0
<b>T= 8 °C</b>									
Heating power	kW	573,0	93,0	803,0	130,0	1032,0	167,0	1263,0	204,0
Pump power	kW	0,53	0,15	0,62	0,19	0,71	0,26	0,80	0,30
Total power requirement	kW	573,53	93,15	803,62	130,19	1032,71	167,26	1262,80	204,30
Produced energy	kW	481,0	0,0	673,0	0,0	866,0	0,0	1059,0	0,0
<b>T= 12 °C</b>									
Heating power	kW	552,0	72,0	773,0	101,0	995,0	130,0	1217,0	159,0
Pump power	kW	0,53	0,15	0,62	0,19	0,70	0,26	0,80	0,30
Total power requirement	kW	552,53	72,15	773,62	101,19	995,70	130,26	1217,80	159,30
Produced energy	kW	481,0	0,0	673,0	0,0	866,0	0,0	1059,0	0,0

Compared with the above tested variants, an elevated pressure increased the power required for both the gas preheating and the power produced by the turbo expander.

By comparing the power balance of the 10 000 m<sup>3</sup>/h and 4 °C at 45 bar and 55 bar, it can be seen that a higher power requirement is due to the higher inlet pressure, but the recoverable power by the turbo expander will also increase. This can be explained by the higher amount of cold energy due to the increased pressure. Due to the higher inlet pressure, it is necessary to maintain a higher temperature in the preheating process which requires a higher amount of water due to the pressure build-up to meet the boundary conditions of the outlet point of the gas transfer station.

It can be stated that in the case of higher-temperature natural gas there is a lower pre-heating demand, thus ultimately less power and energy demand for pressure regulation. It can be stated that at higher natural gas temperatures the process of pressure regulation with the turbo expander can be operated more economically.

### 5.2.2 Examination of Medium Capacity Gas Transfer Station

The gas transfer stations in this category are further away from the compressor station and the number of supplied consumers is smaller. The presumed arrival pressure is between 35 and 40 bar, the maximum capacity of the gas transfer station is in the range of 3,000 to 6,000 m<sup>3</sup>/h.

**INVESTIGATION OF PRESSURE REGULATOR REPLACEMENT BY TURBO EXPANDER IN HUNGARIAN GAS TRANSFER STATIONS**

Anna Bella Galyas; László Tihanyi; István Szunyog; László Kis

Table 3 The amount of produced energy at medium capacity gas transfer station

	Unit	35 bar				40 bar			
		Q=3,000 m <sup>3</sup> /h		Q=6,000 m <sup>3</sup> /h		Q=3,000 m <sup>3</sup> /h		Q=6,000 m <sup>3</sup> /h	
		Exp.	Valve	Exp.	Valve	Exp.	Valve	Exp.	Valve
<b>T= 4 °C</b>									
Heating power	kW	130,0	18,0	259,0	36,0	143,0	22,0	286,0	44,0
Pump power	kW	0,35	0,10	0,41	0,11	0,42	0,12	0,48	0,13
Total power requirement	kW	130,35	18,10	259,41	36,11	143,42	22,12	286,48	44,13
Produced energy	kW	<b>113,0</b>	<b>0,0</b>	<b>225,0</b>	<b>0,0</b>	<b>122,0</b>	<b>0,0</b>	<b>244,0</b>	<b>0,0</b>
<b>T= 8 °C</b>		<b>Exp.</b>	<b>Valve</b>	<b>Exp.</b>	<b>Valve</b>	<b>Exp.</b>	<b>Valve</b>	<b>Exp.</b>	<b>Valve</b>
Heating power	kW	124,0	93,0	248,0	24,0	137,0	16,0	275,0	32,0
Pump power	kW	0,35	0,15	0,39	0,16	0,43	0,17	0,51	0,17
Total power requirement	kW	124,35	93,15	248,39	24,16	137,43	16,17	275,51	32,17
Produced energy	kW	<b>113,0</b>	<b>0,0</b>	<b>225,0</b>	<b>0,0</b>	<b>122,0</b>	<b>0,0</b>	<b>244,0</b>	<b>0,0</b>
<b>T= 12 °C</b>		<b>Exp.</b>	<b>Valve</b>	<b>Exp.</b>	<b>Valve</b>	<b>Exp.</b>	<b>Valve</b>	<b>Exp.</b>	<b>Valve</b>
Heating power	kW	118,0	7,0	236,0	13,0	131,0	10,0	263,0	20,0
Pump power	kW	0,35	0,15	0,40	0,19	0,45	0,23	0,54	0,26
Total power requirement	kW	118,35	7,15	236,40	13,19	131,45	10,23	263,54	20,26
Produced energy	kW	<b>113,0</b>	<b>0,0</b>	<b>225,0</b>	<b>0,0</b>	<b>122,0</b>	<b>0,0</b>	<b>244,0</b>	<b>0,0</b>

In Table 3, the elements of the energy balance change in the same way as in the case of medium gas flows and pressures as in the case of high pressure capacity stations. In addition to a given natural gas flow rate, the theoretical energy balance is more favourable if the temperature of the arriving natural gas is higher, as this results in a reduction in the demand for gas preheating. Based on the above, it can be said that, if the pressure is higher, the theoretical gain is greater from the process, but more energy is needed. Overall, the change is unfavourable.

**5.2.3 Examination of Small Capacity Gas Transfer Station with Small Inlet Pressure**

If the gas transfer station is far away from the compressor station, the inlet pressure of the station is small, it is in the range of 25 to 30 bar compared to the previous categories. This is accompanied by a small maximum load, assuming a hourly natural gas quantity of 1,000 to 2,000 m<sup>3</sup>.

Table 4 shows that very little performance values have been reported in each element of the theoretical energy balance compared to the previous two categories.

Table 4 The amount of produced energy at small capacity gas transfer station

	Unit	25 bar				30 bar			
		Q=1,000 m <sup>3</sup> /h		Q=2,000 m <sup>3</sup> /h		Q=1,000 m <sup>3</sup> /h		Q=2,000 m <sup>3</sup> /h	
		Exp.	Valve	Exp.	Valve	Exp.	Valve	Exp.	Valve
<b>T= 4 °C</b>									
Heating power	kW	33,0	3,5	65,0	7,0	38,0	5,0	75,0	10,0
Pump power	kW	0,20	0,10	0,22	0,11	0,22	0,12	0,22	0,13
Total power requirement	kW	33,20	3,10	65,22	7,11	38,22	5,12	75,22	10,13
Produced energy	kW	<b>2,20</b>	<b>3,10</b>	<b>5,22</b>	<b>7,11</b>	<b>4,22</b>	<b>5,12</b>	<b>7,22</b>	<b>10,13</b>
<b>T= 8 °C</b>		<b>Exp.</b>	<b>Valve</b>	<b>Exp.</b>	<b>Valve</b>	<b>Exp.</b>	<b>Valve</b>	<b>Exp.</b>	<b>Valve</b>
Heating power	kW	31,0	1,5	61,0	2,5	37,0	3,0	71,0	6,0
Pump power	kW	0,20	0,10	0,20	0,10	0,22	0,12	0,21	0,13
Total power requirement	kW	31,20	1,60	61,20	2,60	37,22	3,12	71,21	6,13
Produced energy	kW	<b>30,0</b>	<b>0,0</b>	<b>60,0</b>	<b>0,0</b>	<b>34,0</b>	<b>0,0</b>	<b>68,0</b>	<b>0,0</b>
<b>T= 12 °C</b>		<b>Exp.</b>	<b>Valve</b>	<b>Exp.</b>	<b>Valve</b>	<b>Exp.</b>	<b>Valve</b>	<b>Exp.</b>	<b>Valve</b>
Heating power	kW	30,0	0,5	60,0	1,0	34,0	1,0	64,0	2,0
Pump power	kW	0,20	0,10	0,20	0,08	0,21	0,11	0,20	0,12
Total power requirement	kW	30,20	0,15	60,20	1,08	34,21	1,11	64,20	2,12
Produced energy	kW	<b>30,0</b>	<b>0,0</b>	<b>60,0</b>	<b>0,0</b>	<b>34,0</b>	<b>0,0</b>	<b>68,0</b>	<b>0,0</b>



**INVESTIGATION OF PRESSURE REGULATOR REPLACEMENT BY TURBO EXPANDER IN HUNGARIAN GAS TRANSFER STATIONS**

Anna Bella Galyas; László Tihanyi; István Szunyog; László Kis

It can be stated, therefore, that in the case of stations with small arriving pressure and small gas flow, the importance of energy production with turbo expander units is negligible. It can be stated that the replacement of the pressure regulating equipment by a turbo expander in gas

transfer stations at such conditions cannot be proposed energetically.

Figure 4 shows a summary of the results of the versions presented so far. On the vertical axis, the theoretical performance of the turbo expander unit is presented in the process, expressed in units of kW.

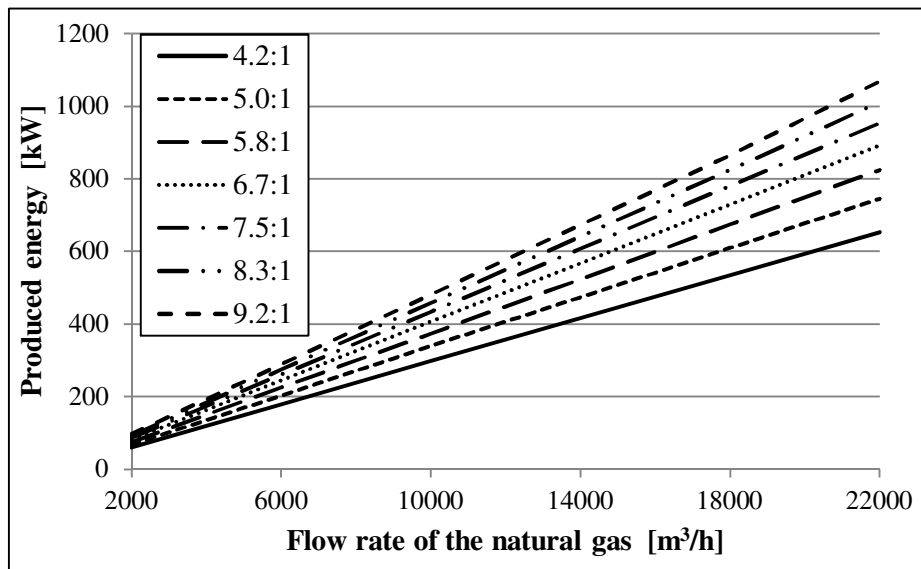

Figure 4 Theoretical production of electricity, depending on the pressure ratio and the amount of natural gas

The horizontal axis shows the maximum gas flow of the gas transfer stations, in m<sup>3</sup>/h unit. Each curve expresses the pressure ratio that can be derived from the inlet pressure of the gas transfer station and from the fixed 6 bar outlet pressure considered as the base parameter. Of course, the pressure reduction process from 25 bar to 6 bar has a ratio of 4.2: 1, a pressure ratio of 5.0: 1 for the process from 30 bar to 6 bar, and thus the maximum 55 bar for which the pressure ratio of 9.2: 1 is given in the figure above.

In Figure 4, only the amount of energy extracted by the turbo expander was depicted, without the power required to preheat the natural gas. Observing the figure, all pressure curves are located at almost a single starting point for a gas transfer station with a load of 2,000 m<sup>3</sup>/h. As the maximum flow rate of the gas transfer station increases, the amount of energy that can be produced increases. It can also be observed that at higher pressure ratios, more energy production can be achieved. In the case of a gas transfer

station with a maximum capacity of 22,000 m<sup>3</sup>/h, higher power generation occurs when the specified end point conditions are 0 °C and 6 bar achieved by an inlet pressure of 55 bar and not the minimum pressure of 25 bar.

Figure 5 depicts temperature change curves for turbo expander and for conventional pressure control valve, as a function of pressure drop. At the inlet point of the turbo expander, a significantly higher temperature is required to ensure that at the end of the isentropic process the natural gas temperature is above 0 °C. It can be seen from the figure that at a pressure drop of 19 bar, in the case of isenthalpic throttle, only a decrease of 10.7 °C occurs; the isentropic expansion results in a decrease of approximately 74 °C. Obviously, increasing pressure drop is associated with an increasing temperature change. At 49 bar pressure change, in the case of isenthalpic case the temperature difference slightly exceeds 20 °C; in the isentropic 120 °C is required to meet the 0 °C criteria.

**INVESTIGATION OF PRESSURE REGULATOR REPLACEMENT BY TURBO EXPANDER IN HUNGARIAN GAS TRANSFER STATIONS**

Anna Bella Galyas; László Tihanyi; István Szunyog; László Kis

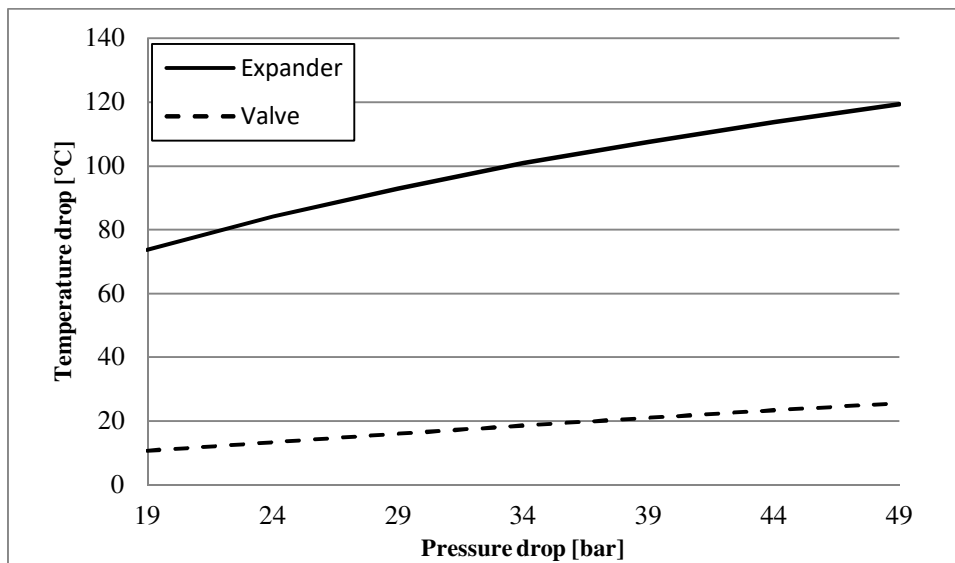

Figure 5 Temperature drop depending on pressure drop

## 6 Conclusion

The replacement of pressure regulators installed at the gas transfer stations with turbo expander has been applied since the 1980s. Using cold energy that can be extracted during the isentropic pressure regulating process, electricity can be generated using a connected generator, which is widely used.

The energy efficiency of the turbo expander installed at the domestic gas transfer stations was investigated, to which the Aspen HYSYS simulation software was used. The fulfilment of the 0 °C and 6 bar criteria set forth in ÜKSZ was considered to be the basic condition in order to ensure the supply of high-medium distribution network through the gas-transfer station in a regulated framework.

The simulation could be implemented using a model by installing a turbo expander unit on the control branch. On the parallel control line a conventional pressure control valve was used.

It has been found that the replacement of pressure control valves is highly desirable for gas transfer stations with high pressure and high gas flow. In the case of a large (22,000 m<sup>3</sup>/h) gas load, up to 1 MW of theoretical energy can be extracted from the pressure regulating process. In the case of medium and low-arrival pressure and capacity stations, however, there is a lower level of energy production, which is why it is not advisable to install turbo expander.

We have found that turbo expander pressure regulation requires very high temperatures in front of the unit to meet the output side 0 °C temperature criteria. Therefore, the gas should be heated to a higher temperature than that of the isenthalpic throttle. Thus, the boiler for preheating requires greater power than in the case using a control valve. Since

it is a gas boiler, it does not use electricity, but uses natural gas for its own use, which the natural gas transmission system operator can account for at a significantly lower price.

The expansion of the expansion turbines on gas transfer stations is becoming more common in the world, and many examples serve as evidence. More and more projects and studies deal with the topic around the world, as the latency inherent in the process seems to be justified from an energy management point of view.

## Acknowledgments

The described work/article was carried out as part of the „Sustainable Raw Material Management Thematic Network – RING 2017”, EFOP-3.6.2-16-2017-00010 project in the framework of the Széchenyi2020 Program. The realization of this project is supported by the European Union, co-financed by the European Social Fund.

## References

- [1] A Framework Strategy for a Resilient Energy Union with a Forward-Looking Climate Change Policy, European Commission, COM(2015) 80 final, 2015.
- [2] TIHANYI, L., ZSUGA, J.: Földgázszállító rendszerek tervezése és létesítése, University of Miskolc, ISBN 978-963-661-999-2, 2012. (Original in Hungarian)
- [3] TIHANYI, L., CHOVÁN, P.: Gázszállító rendszerek energetikai elemzése, Magyar Energetika, Vol. 22, Issue 4, pp. 40-43, 2015. (Original in Hungarian)
- [4] A Magyar Földgázrendszer Üzemi és Kereskedelmi Szabályzata (2015), Available:

**INVESTIGATION OF PRESSURE REGULATOR REPLACEMENT BY TURBO EXPANDER IN HUNGARIAN GAS TRANSFER STATIONS**

Anna Bella Galyas; László Tihanyi; István Szunyog; László Kis

- [https://fgsz.hu/sites/default/files/dokumentumok/jogszabalyok/publikalt\\_torzsz\\_6454-2015\\_mekh\\_hat\\_alapjan.pdf](https://fgsz.hu/sites/default/files/dokumentumok/jogszabalyok/publikalt_torzsz_6454-2015_mekh_hat_alapjan.pdf) (Original in Hungarian)
- [5] Interstate Natural Gas Association of America Waste Energy Recovery Opportunities for Interstate Natural Gas Pipelines, Available: <http://www.ingaa.org/file.aspx?id=6210>, 2008.
- [6] ARDALI, E. K., HEYBATIAN, E.: Energy Regeneration in Natural Gas Pressure Reduction Stations by Use of Gas Turbo Expander; Evaluation of Available Potential in Iran, Argentina, 24<sup>th</sup> World Gas Conference, 2009.
- [7] POZIVIL, J.: Use of Expansion Turbines in Natural Gas Pressure Reduction Stations, Acta Montanistica Slovaca, Vol. 9, Issue 3, pp. 258-260, 2009.
- [8] BISIO, G.: Thermodynamic Analysis of the Use of Pressure Exergy of Natural Gas, Energy, Vol. 20, Issue 2, pp. 161-167, 1995.
- [9] BLOCH, H., SOARES, C.: Turboexpanders and Process Applications, Gulf Professional, ISBN 978-0-88415-509-6, 2001.
- [10] DELGADO CALIN, G.: Energy Efficiency Projects with Turboexpanders Application to Combined Cycle Power Plants, 20<sup>th</sup> International Congress on Project Management and Engineering, Cartagena, 2016.
- [11] ELSOBKI, M.: Boosting Capacity of Electric Generation through the use of Turbo expanders in Natural Gas Network, Egyptian German High Level Joint Committee for Renewable Energy, Energy Efficiency and Environmental Protection, Available: <http://egyptera.org/Downloads/events/Turboexpander%20Report,%2024%20Nov.-MSE.pdf>, 2013.
- [12] FARZANEH-GORD, M., MANZARI, M., MAGRABI, M., HASHEMI, S., EFTEKHARI, H., FAROKHI, A.: Using pressure exergy of natural gas in Bandar-Abbas refinery gas pressure drop station, The second International conference on Modeling, Simulation, And Applied optimization, Abu Dhabi, UAE, 2007.
- [13] RAHMAN, M.: Power generation from pressure reduction in the natural gas supply chain in Bangladesh, Journal of Mechanical Engineering, Vol. 41, Issue 2, pp. 89-95, 2010.
- [14] RHEUBAN, J.: Turbo expanders, Harnessing the Hidden Potential of Our Natural Gas Distribution System, Available: <http://jacobrheuban.com/2009/03/09/turboexpanders-harnessing-the-hidden-potential-of-our-natural-gas-distribution-system/>, 2009.
- [15] KOWALA, D.: Using the gas pressure potential for electricity generation at Pressure Reduction Stations, GERG Academic Network Event, Brussels, 2007.

**Review process**

Single-blind peer review process.

## BIOMEDICAL ENGINEERING AND PROTEOMICS

**Marianna Trebuňová**

Technical University of Košice, Faculty of Mechanical Engineering, Department of Biomedical Engineering and Measurement, Letná 9, 042 00 Košice, Slovakia, marianna.trebunova@tuke.sk (corresponding author)

**Jozef Živčák**

Technical University of Košice, Faculty of Mechanical Engineering, Department of Biomedical Engineering and Measurement, Letná 9, 042 00 Košice, Slovakia, jozef.zivcak@tuke.sk

**Keywords:** proteomics, proteins, genes

**Abstract:** The term "proteomics" was created in 1997, by analogy of genomics, genome studies. "Proteom" refers to a mixture of proteins and genome and was created by Marcom Wilkins in 1994. Proteomics is the large-scale study of proteins, particularly their structures and functions. Proteins are vital parts of living organisms, as they are the main components of the physiological metabolic pathways of cells. After genomics and transcriptomics, proteomics is the "next step" in the study of biological systems. It is more complicated than genomics because an organism's genome is approximated by the constant, whereas the proteome differs from cell to cell and from time to time. Distinct genes are expressed in different cell types, which means that even the basic set of proteins that are produced in a cell needs to be identified.

### 1 Defining proteomics goals

Protein study, determination of its amount, primary structure, higher structures, their functions and changes under different conditions is not a new task of biological sciences. At the turn of the 20th and 21st centuries, however, two new moments began to be more prominent in this endeavor. Despite the significant contribution of molecular genetics to many issues, we still can not give a satisfactory response, including the answer to the question of how and how many genes a function performs. If one gene only corresponds to one final product, then one would have no more than 25,000 proteins. Since proteins are the centerpiece in understanding cellular functions as well as disease processes, without knowing the relationship between genes and proteins, it is not possible to make effective use of the knowledge of the genomic era. In 1994, the role of proteomics was defined as the identification and characterization of all proteins expressed in the organism, but it soon became apparent that its role was also to determine the amount, function, localization and post-translational modification of these proteins present in the cell at a given moment. The truth has not been as well defined because it has not evaluated the effect of enviromechanical, metabolic, pharmacological, genetic and pathological conditions on the proteome. We can summarize that the goal of proteomics is to get a global and integrated view of biology by studying the complete cell protein network rather than by studying individual proteins. The second goal is not only to identify proteins, but also to understand their function and structure and to create a 3D map of the cells (to determine the localization of the individual proteins). Another significant milestone for the above-mentioned goals has also been the unprecedented methodological possibilities of separation and analysis of proteins using a

robust technique that is able to provide the desired proteomic data much faster, more reliably and more accurately.

Today, we are aware that the path from genomics to proteomics would not have been possible without the application of improved bioengineering techniques using mass spectrometry principles. There is probably no other current technique that would overcome the mass spectrometer in a variety of applications in basic and applied research as well as in diagnostics [1].

### 2 Why is not the number of proteins consistent with the number of genes?

Thanks to molecular genetics and its methods we know the composition of the genome (nucleotide sequence) of many microorganisms, model higher organisms as well as genome of its own kind. However, the nucleotide structure of the gene is only a chemical information template. And although this information for knowledge and practice is extremely valuable, it does not give a satisfactory answer to the question of what is in fact the functional radius of this information. We know that the genome consists of only about 25,000 genes and not 100,000 than originally assumed. On the other hand, there are estimates that the total number of protein variants, including post-translational ones, can be as high as 300,000 in humans. How could more proteins be produced from a given number of genes? Current known solutions to this paradox are at the RNA level as well as at the level of the synthesized proteins.

One answer is that each gene can encode more proteins in a process called alternate splicing. Alternative splicing means that one gene can produce different mRNA products, and thus different proteins. Another answer is that one protein can be chemically modified after it is



synthesized so as to obtain another function. The third answer is that proteins interact with each other in complex ways that could change their function. Thus, one gene can produce several, functionally different proteins in many different ways.

The known mechanisms of the formation of functionally different protein variants by post-translational processing include acetylation, phosphorylation,

adenylation, adenosyl ribosylation, glycosylation and the like. Other changes may be caused by cleavage of a part of the chain or modification of the amino acid residues [1].

Some primary transcripts (for mRNA) undergo alternate splicing, which will allow the formation of two or more types of mRNA. Polyadenylation may also affect the final mRNA structure. These processes are illustrated in Figure 1.

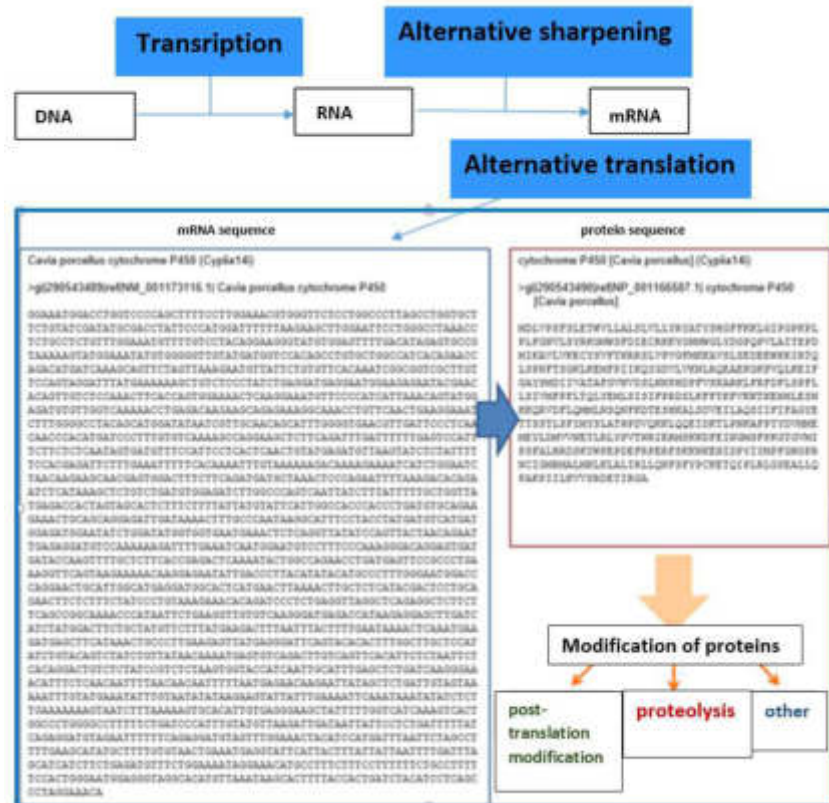

Figure 1 The emergence of different proteins.

### 3 Proteins

Proteins are polymer chains composed of monomers called amino acids. Proteins are an essential part of every biological system and participate in every process in the cell. Together with nucleic acids, lipids and sugars, they form a group of biopolymers that condition the existence of living systems.

Functions and importance of proteins: Enzyme proteins - biocatalysts of many chemical reactions in biological systems, transport proteins - transfer of necessary substances to preserve life inside the biological organism (myoglobin, hemoglobin, serum albumin). Protective proteins - Protective function (immunoglobulins), regulatory proteins - hormones - control and regulation

molecules (insulin, somatotropin, growth hormones), structural proteins (collagen, elastin) and receptor proteins - serving as external signal receptors.

We distinguish four protein structures (Figure 2): primary structure - amino acid sequence in the polypeptide chain, secondary structure - local 3-D "folding" of the polypeptide chain - the most commonly occurring structures:  $\alpha$ -helix, - a loop, a tertiary structure - the total 3-D structure of the polypeptide, comprising a spatial arrangement of the side chains and the geometry of the arrangement between the distant portions of the polypeptide chain and the quaternary structure - the mutual arrangement of several polypeptides in the protein [2-4].

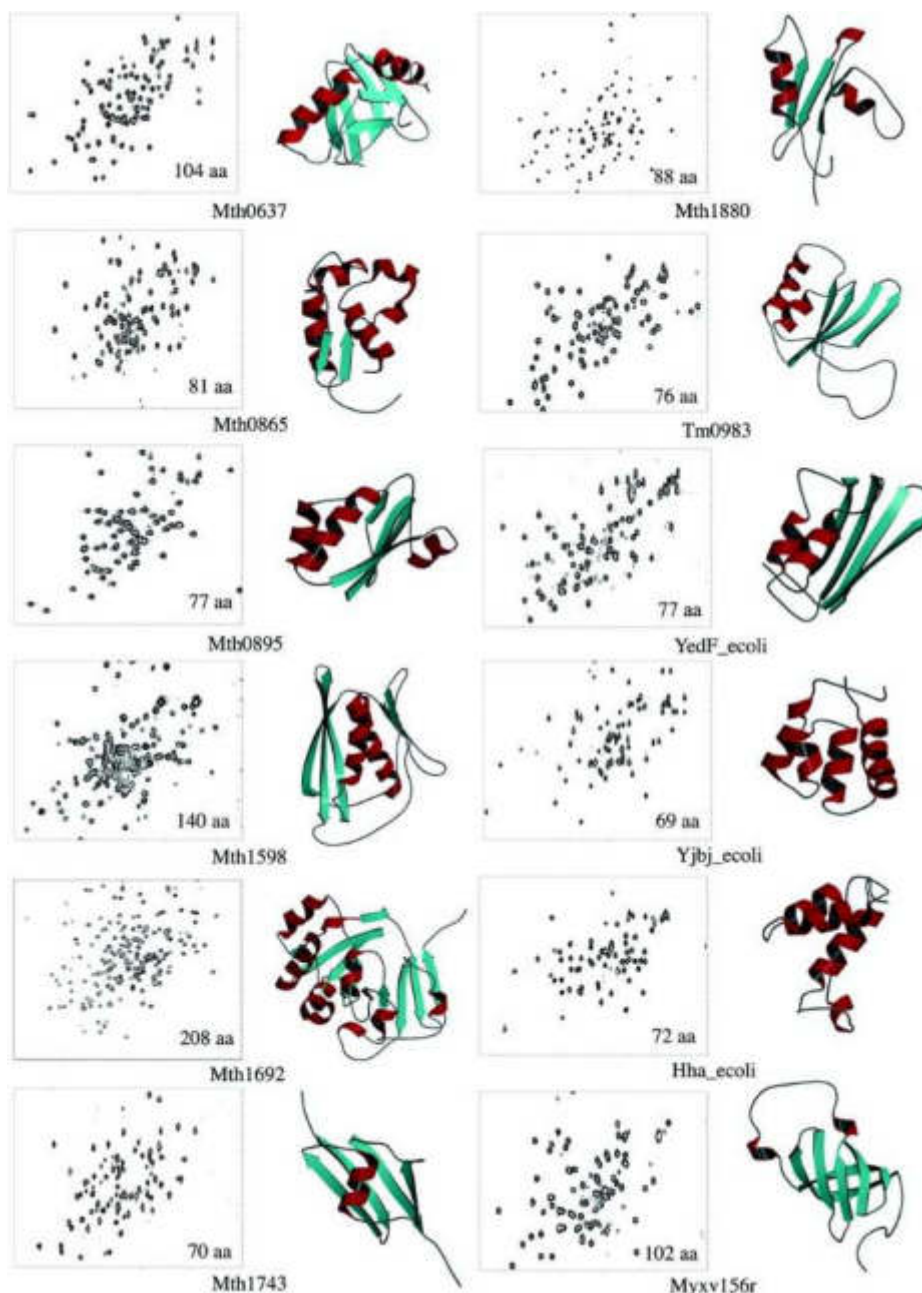

Figure 2 Protein structures [2,3]

### 3.1 Protein folding

Protein folding is a physical process in which the polypeptide chain is packed into a characteristic 3D structure for a given protein (Figure 3). The mechanism of the folding protein has not yet been explicitly explained, and this remains one of the most attractive unresolved problems in science. The 3D structure of proteins is determined by the amino acid sequence in the polypeptide chain under the physicochemical conditions (temperature, pH, ionic strength, solvent type).

It is generally accepted that the minimization of hydrophobic amino acid contacts with water molecules is the "driving force" of the packaging process, but the

contribution of other interactions must also be taken into account (in particular, the formation of hydrogen bonds between the amino acid residues together as well as the binding of these molecules with the solvent molecules). The process of in-vivo protein packaging often takes place during the synthesis of the polypeptide chain on ribosomes. The N-terminus of this chain is already bundled while the C-terminus of the polypeptide is still synthesized. In this process, chaperones play a very important role. Chaperones are molecules (of protein origin) that allow proper packaging of proteins in vivo and prevent the formation of protein aggregates. The rate of protein aggregation depends on the size of the protein and the outer

packing conditions. Small single-domain proteins are able to acquire their native 3D structure in a few milliseconds. Packing large multisubunit proteins takes place over several intermediates and can take several dozen minutes or even hours. The number of possible different conformations of the polypeptide chain is very large (e.g., for a polypeptide consisting of 300 amino acids this number is 10<sup>143</sup>). So, if the process of protein collision was randomized through all the possible conformational states, it would take this process for a long time (time longer than the age of the universe), but the proteins are getting too quickly - the Levinthal paradox. It is clear that the folding protein can not be accomplished by randomly searching for the "correct" conformational state of the protein. Incorrectly packed proteins are responsible for several inflammatory diseases: Creutzfeldt-Jacobs disease, bovine spongiform encephalopathy, amyloid plaque formation and spleen (Alzheimer's disease). All of these diseases are caused by the formation of aggregates of improperly packed proteins. In the case of Alzheimer's disease, it is the formation of amyloid plaques from the amyloid B protein (the proteolytic product of the amyloid precursor protein). At high concentrations, these proteins change their tertiary structure, resulting in their aggregation. The amyloid plaques thus formed are deposited around the neurons [4].

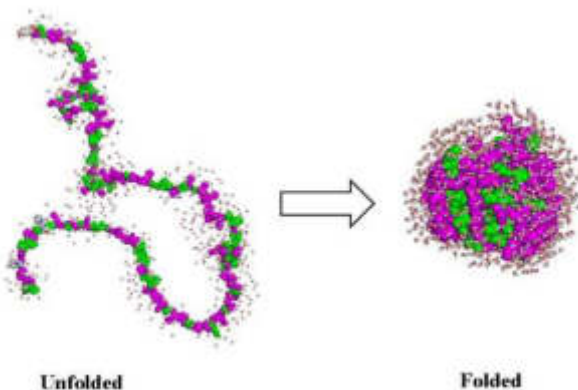

Figure 3 Protein folding [5]

#### 4 Scheme of current proteomics

Figure 4 shows a graphical representation of proteomics and its other disciplines.

*Structural proteomics* - its goal should be to determine the structure, the amount of proteins including the proportion of post-translationally modified molecules, the mutual protein interactions, as well as the relationship of protein variants to the structure of the gene. It may also lead to the creation of protein maps for different cell types with different physiological and pathological conditions.

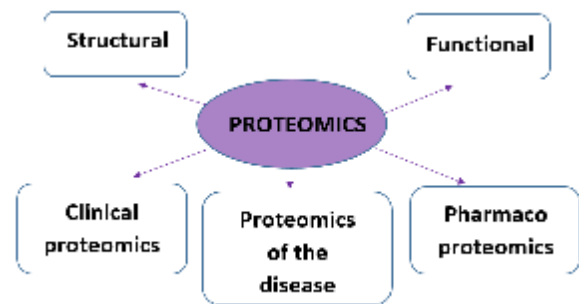

Figure 4 Current proteomics

*Functional Proteomics* - The amount of individual proteins is affected by transcription factors. These are factors that enter the nucleus and bind to specific DNA segments (enhancers, promoters). These factors can interact directly or indirectly with the transcription apparatus. Furthermore, there is the influence of epigenetic factors (imprints caused by different gene-methylation methylation). Functional state of proteins can be explained by post-translational modifications of proteins, especially phosphorylation, glycosylation. Functional proteomics will help to elucidate enzyme catalysis, transport functions, immunity, nerve impulse transmission, growth regulation, and cell differentiation. It could also help explain the processes of aging and the different predisposition to disease.

*Proteomics of the disease* - has the potential to capture pathology at an early stage, to determine more precisely the etiopathogenesis and individual variability of molecular phenomena. It will play an important role in elucidating the mechanisms of cancer, neurodegenerative, psychological (Alzheimer's, Parkinson's disease, schizophrenia), inflammatory and metabolic diseases. The fastest development can be observed in oncoproteomics. Survival, Growth, Invasiveness of Tumor Cells - At the root of the genetic defect, there must also be alteration of functional proteins. The proteomic approach will provide important information about altered cellular signaling paths.

*Clinical Proteomics* - The goal is to discover, find proteins that will be of medical significance. These are proteins that can be used as diagnostic markers because their expression under specific physiological and pathological conditions will be significantly increased (inflammatory, infectious, cancerous). Comparing the sensitivity and specificity parameters of most of the onome markers with proteomic markers favor the use of proteomic markers.

*Pharmacoproteomics* - Knowing specific proteomic changes in various diseases can influence the decision to select appropriate therapy. At the same time, therapy efficacy and toxicity could be monitored at the level of protein spectrum changes and their functional status [1].

---

## Conclusions

Nowadays proteomics is not applied in the Slovak Republic either in medical-oriented research or in clinical practice. Our aim is to provide information on the current possibilities of proteomics, but also to point out weaknesses in the development of this department in the SR. The advancement of the company in strategic sectors such as proteomics is a strong support for both medical and biomedical engineering applications [1].

## Acknowledgement

This article was supported by the state grants KEGA 069TUKE-4/2017(50%) of the Ministry of Education of the Slovak Republic and APVV-15-0356 (50%) MEDPEEK.

## References

- [1] [www.fnsdba.sk/aktuality-subory/postery/C19.ppt](http://www.fnsdba.sk/aktuality-subory/postery/C19.ppt) 2018. (Original in Slovak)
- [2] KRAULIS, P.J.: MOLSCRIPT: a program to produce both detailed and schematic plots of protein structures, *Journal Appl Crystallogr*, Vol. 24, pp. 946–950, 1991.
- [3] <http://www.pnas.org/content/99/4/1825>, 2018.
- [4] <https://www.upjs.sk/public/media/4354/Biofyzika08.pdf>, 2018. (Original in Slovak)
- [5] <https://step1.medbullets.com/biochemistry/102094/protein-folding-and-degradation>, 2018.

## Review process

Single-blind peer review process.





---

## JOURNAL STATEMENT

---

Journal name:	<b>Acta Tecnología</b>
Abbreviated key title:	Acta Technol
Journal title initials:	AT
Journal doi:	10.22306/atec
ISSN:	2453-675X
Start year:	2015
The first publishing:	October 2015
Issue publishing:	Quarterly
Publishing form:	On-line electronic publishing
Availability of articles:	Open Access Journal
Journal license:	CC BY-NC
Publication ethics:	COPE, ELSEVIER Publishing Ethics
Plagiarism check:	Worldwide originality control system
Peer review process:	Single-blind review at least two reviewers
Language:	English
Journal e-mail:	<b>info@actatecnologia.eu</b>

The journal focuses mainly for the original and new, interesting, high-quality, theoretical, practical and application-oriented contributions to the field of science and research as well as to pedagogy and education in the field of technologies.

Publisher:	<b>4S go, s.r.o.</b>
Address:	Semsa 24, 044 21 Semsa, Slovak Republic, EU
Phone:	+421 948 366 110
Publisher e-mail:	<b>info@4sgo.eu</b>

**Responsibility for the content of a manuscript rests upon the authors and not upon the editors or the publisher.**