

Received: 10 Jan. 2026; Revised: 17 Feb. 2026; Accepted: 18 Mar. 2026
<https://doi.org/10.22306/atec.v12i1.313>

Applications of IDMA technology in US Patents

Muhanned AL-Rawi

Bandung Institute of Technology, Jl. Ganesa No.10, Lb. Siliwangi, Kecamatan Coblong, Kota Bandung, Jawa Barat
40132, Indonesia, muhrawi@yahoo.com

Keywords: US Patents, IDMA, working principles, advantages.

Abstract: Interleave Division Multiple Access (IDMA) is a promising multiple access technique for wireless communication systems because of its potential to enhance spectral efficiency, mitigate interference, and support reliable multi-user transmission. This paper presents the fundamental principles of IDMA, with emphasis on user-specific interleaving, symbol mapping onto available time slots, and the corresponding deinterleaving and recovery process at the receiver. The main advantages of IDMA are discussed, including improved spectral efficiency, better error performance, lower implementation complexity, flexibility for diverse wireless environments, and increased communication security through user-specific interleaver sequences. In addition to the theoretical overview, the paper reviews selected United States patents related to IDMA and closely associated non-orthogonal multiple access approaches published between 2020 and 2025. The analysed patents cover a wide range of applications, including narrowband machine-type communication, random access procedures, asynchronous coded multiple access combined with OFDM, wireless network control, storage systems, and joint transmissions in shared wireless resources. The review demonstrates that IDMA principles continue to be adapted and extended in response to the evolving requirements of modern wireless communication technologies. The examined patent activity confirms the ongoing technological relevance of IDMA and related multiple access schemes and highlights their potential for efficient, scalable, and interference-resilient communication in advanced wireless networks.

1 Introduction

The available frequency spectrum and time slots are shared by users of the IDMA multiple access scheme. To distribute the data symbols across the available time slots, each user in IDMA is given a distinct interleaver sequence. Through the reduction of multipath fading and interference, this procedure aids in enhancing the communication system's performance.

Interleavers of various kinds, such as block, convolutional, and turbo interleavers, can be used to implement IDMA. The system's particular needs and the intended performance determine the type of interleaver to use. Block interleavers are the most basic kind of interleavers, whereas turbo interleavers are the most intricate.

1.1 Working principles

The fundamental idea behind IDMA is to interleave the data symbols throughout the time slots that are available. To distribute the data symbols over the available time slots, each user is given a distinct interleaver sequence. The interleaving process disperses the data symbols over a longer time span, which lessens the effects of interference and multipath fading.

IDMA's interleaving procedure (see Fig. 1) includes the subsequent steps:

1. Data Symbol Generation: The transmitter creates data symbols.
2. Interleaving: A distinct interleaved sequence that is assigned to every user is used to interleave the data symbols.
3. Mapping: The available time slots are mapped onto the interleaved data symbols.
4. Transmission: The wireless channel is used to send the mapped data symbols.

At the recipient (refer to Figure 1), the original data symbols are recovered using the inverse procedure. The inverse interleaver sequence that is assigned to each user is used to deinterleave the received data symbols after they have been demapped from the time slots. The original data is then recovered using the demodulated data symbols.

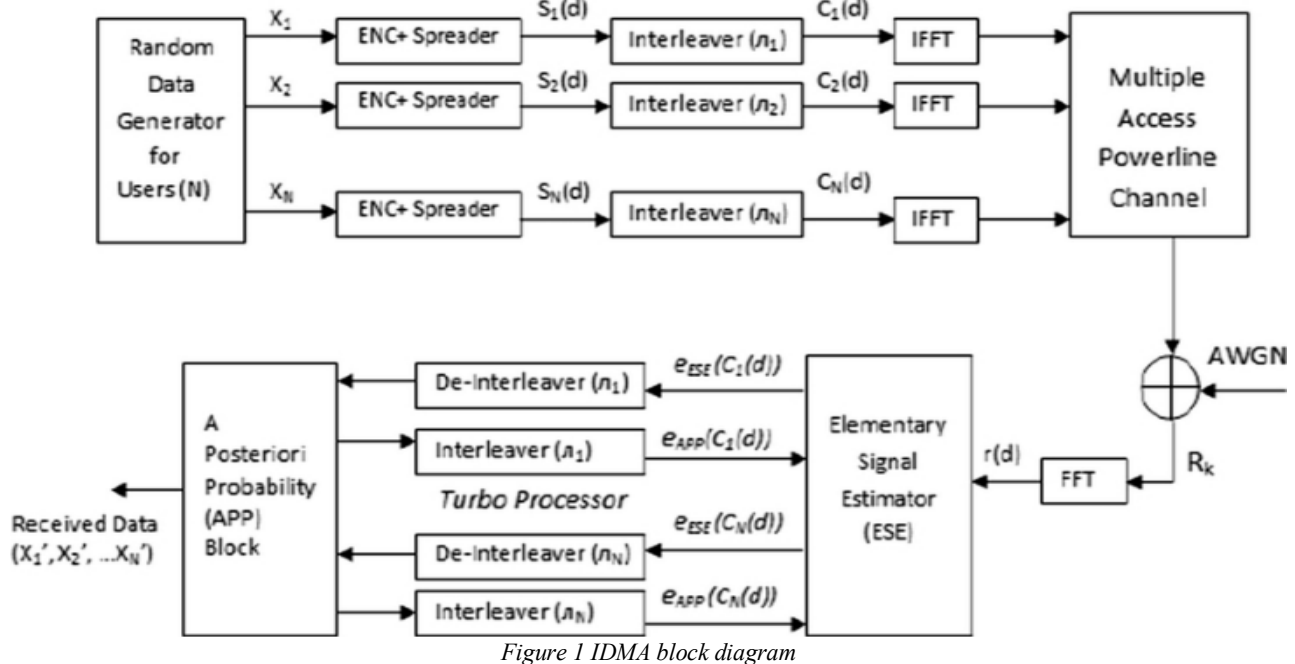

Figure 1 IDMA block diagram

1.2 Advantages of IDMA

Compared to other multiple access schemes, IDMA offers the following benefits:

- 1-Improved Spectral Efficiency: By effectively utilizing the available frequency spectrum and time slots, IDMA can offer higher spectral efficiency than other multiple access schemes, like CDMA and TDMA.
2. Better Error Performance: By lessening the effects of interference and multipath fading, IDMA can offer better error performance.
3. Low Complexity: Compared to other schemes like CDMA, IDMA is a straightforward and effective multiple access scheme that requires less sophisticated hardware and processing.
- 4-Flexibility: IDMA is an adaptable multiple access scheme that works well in a variety of wireless communication settings and uses.
5. Security: By employing distinct interleaver sequences for every user, IDMA can enhance security by making it more difficult for unauthorized users to gain access to the network.

1.3 Applications of IDMA

IDMA has a number of potential uses in wireless communication systems, such as:

- 1-Mobile Communication Systems: IDMA can be used to enhance network performance and coverage in mobile communication systems like 3G, 4G, and 5G.
2. Satellite Communication Systems: To increase transmission efficiency and lessen the effects of multipath fading and interference, satellite communication systems can employ IDMA.
3. Wireless Sensor Networks: IDMA can be applied to wireless sensor networks to enhance network performance and energy efficiency.

2 Applications of IDMA in US Patents

The deployment of Internet of Things (IoT) interconnected devices where one or more user equipment is configured for uplink transmission with one or more uplink time-frequency regions for enhanced Machine Type Communication Non-Orthogonal Multiple Access uses an uplink non-orthogonal multiple access for narrowband machine type communication in [1]. A demodulation reference signal cyclic shift assignment, orthogonal cover code assignment, interleaver assignment, starting subframe periodicity, starting subframe offset, time duration in each period, and one or more signal thresholds are defined and signaled as part of the configuration.

The present disclosure in [2] pertains to a communication system that supports higher data rates than 4.sup.th-generation (4G) systems, such as Long Term Evolution (LTE), and is either pre-5 .sup.th-generation (5G) or 5G. The current disclosure pertains to the technical area of wireless communication, specifically to a random access method. The process involves sending a random access signal along with a payload from a terminal to a base station. The preamble sequence is set randomly or based on the size of the data to be sent, and the payload is set up based on the current service requirements. The terminal then receives feedback information that is sent back by the base station and corresponds to

the random access signal. This feedback information includes at least one of the following: timing advance information, uplink transmission grant information, acknowledgement, and unique user identification information. By designing the random access signal so that it includes both the payload and the preamble sequence, the current solution can reduce access delay in data transmission by using two interactive steps to realize the function that is realized through four interactive steps in the prior art.

Numerous innovative ideas and plans related to non-orthogonal multiple access for wireless communications are explained in [3]. In order to decrease multi-user interference (MUI) and enhance performance, a group orthogonal coded access (GOCA) scheme is implemented. To distinguish user equipment (UEs) based on distinct patterns of repetition, a repetition division multiple access (RDMA) scheme is implemented. To lower MUI and boost efficiency, a low-density spreading (LDS) scheme is implemented.

The non-orthogonal multiple access method described in the patent in [4] is accomplished by: choosing a physical resource at random to perform non-orthogonal multiple access among the predefined areas of contention-based data transmission; choosing a reference signal sequence for a contention-based data transmission through the chosen physical resource; choosing a contention resource for the contention-based data transmission; choosing a scrambling sequence to be applied to data transmission in the contention-based data transmission; and transmitting a data channel that contains data and a reference signal corresponding to the chosen reference signal sequence through the chosen physical resource, where the data channel is transmitted by permitting the chosen scrambling sequence to be applied thereto.

In [5], a user's equipment and technique for using Asynchronous Coded Multiple Access (ACMA) in a communication system that uses Orthogonal Frequency Division Multiplexing (OFDM) to transmit a random-access radio frequency (RF) signal are described. A burst with symbols is created by performing an inverse fast Fourier transform on a unique word (UW) multiplexed with the payload; each burst symbol is transmitted in synchrony with successive symbol-start instants; and an information stream is encoded as OFDM symbols using a low rate Forward Error Correction (FEC) coding appropriate for Successive Interference Cancellation (SIC) to form a payload. Within a subset of consecutive symbol-start instants of the burst, the UW contains multiple Zadoff-Chu (ZC)-like sequences. A receiver looks for consecutive ZC-like sequences to identify burst arrival. The UW with an extra ZC-like sequence can be used to estimate the channel state.

The electronic device and method for interleaved multiple access communication are disclosed in [6]. The processing circuit of an electronic device for an interleaved multiple access control terminal is set up to gather information about interleaved multiple access communication between a transmitting and receiving apparatus; determine configuration parameters for the transmitting apparatus based on the information; and provide the determined configuration parameters to the transmitting apparatus so that the transmitting apparatus is configured with the transmitting parameters for communicating with the receiving apparatus. These parameters include the operation parameters of an interleaver of the transmitting apparatus, which is used to distinguish the transmitting apparatus from other transmitting apparatus.

A method and a device for uplink data transmission using a non-orthogonal code multiple access scheme in a wireless communication system are provided by the patent in [7]. In particular, a base station provides information to a terminal on a codebook unique to that terminal. The codebook for a predetermined multi-dimensional modulation contains the terminal-specific codebook. The terminal creates a complex vector by encoding an information bit using multi-dimensional modulation based on the terminal-specific codebook. In order to produce a frequency signal, the terminal applies DFT to the complex vector using the codebook unique to the terminal. Uplink data produced by applying IFFT to the frequency signal is transmitted by the terminal.

A transmitter can perform channel coding on a bit sequence to determine a coded sequence in [8]. A multiple access method, a multiple access transmitter, and a multiple access receiver. The technique also entails interleaving and/or scrambling the coded sequence, modulating the interleaved and/or scrambled sequence using a multidimensional constellation, grid mapping the modulated symbol sequence to identify a mapped sequence, and then transmitting the mapped sequence. The technique also entails a receiver receiving mixed signals from several transmitters. Each transmitter performs interleaving, scrambling, multidimensional constellation modulation, and grid mapping on the data to produce the mixed signals. The technique also involves the receiver decoding mixed information based on grid mapping pattern information, multidimensional constellation information, and interleaver and/or scrambler information.

In a wireless communication system, an apparatus serves multiple user devices in [9]. Using a non-orthogonal multiple access, or NOMA, scheme, the apparatus transmits and receives a first data signal of the first user equipment and a second data signal of the second user equipment in order to transmit and receive data of a plurality of user equipments, including at least a first user equipment and a second user equipment, on resources shared by the plurality of user equipments. Prior to the first and second data signals being superposed, they are modulated using distinct waveforms.

An electronic device and method for a wireless communication network node and an electric device and method for a wireless communication network control end are included in the current disclosure in [10]. A processing circuit is part of the electronic equipment for the wireless communication network control end. Within a predefined domain, the processing circuit can decide how to divide wireless communication transmission resources, which are then used for a network node's

initial transmission and subsequent transmissions, respectively. Additionally, the processing circuit can produce configuration data that includes details about how the wireless communication transmission resources are divided up.

Each storage controller in [11] is made up of a first storage unit, an interface unit, and a processing unit that communicates a parameter to the interface unit that directs the writing of data in each of n-number of other storage controllers (where n is a natural number of two or more). After receiving the parameter, the interface unit performs the following operations: obtaining the data from the first storage unit and storing it in the second storage unit; creating n-number of requests to write the data to each of the other storage controllers; storing each of the generated requests in n-number of queues that correspond to each of the other storage controllers; processing each request placed in each queue; and moving the data from the second storage unit to each of the other storage controllers.

The apparatus described in [12] consists of an acquisition unit that obtains an information block created from transmission data for a user and is subjected to error correction coding, as well as an interleaving unit that uses a user-specific interleaver to interleave a bit sequence of the information block. By interleaving each of the two or more partial sequences derived from the bit sequence, the interleaving unit interleaves the bit sequence.

A first and a second transmitter are part of a wireless communication system in [13]. The first transmitter is set up for a superimposed non-orthogonal multiple access, or NOMA, which allows the transmission or reception of a first data signal of the first user equipment and a second data signal of the second user equipment on resources shared by the first and second user equipment. The second transmitter is set up for a superimposed non-orthogonal multiple access, or NOMA, which allows the transmission or reception of a third data signal of the first user equipment and a fourth data signal of the second user equipment.

3 Summary and conclusion

All things considered, IDMA is a promising technology with a lot of potential advantages in the wireless communication space. As wireless communication systems develop further, IDMA might play a bigger role in enhancing network effectiveness and performance.

References

- [1] KEATING, R., RATASUK, R., MANGALVEDHE, N., TAN, J., CHEN, J., HSIEH, T.-C.: *Uplink Non-Orthogonal Multiple Access for Narrowband Machine Type Communication*, US-20200008221A1, pp. 1-36, 2020.
- [2] XIONG, Q., YU, B., QIAN, C., FU, J., WANG, Y., ZHANG, Y.: *Method and Device for Performing a Random Access in Wireless Communication System*, US-20200029366A1, pp. 1-28, 2020.
- [3] GAU, G.-H., HUANG, H.-C., CHEN, W.-J., TSAI, C.-W., CHEN, J.-Y., WU, M.-L.: *Non-orthogonal Multiple Access Wireless Communications Methods and Apparatus Thereof*, US-10727897B2, pp. 1-22, 2020.
- [4] LEE, H., KIM, K., KIM, E., LEE, S.: *Method for transmitting/detecting data on the basis of non-orthogonal multiple access method, and device therefor*, US-10756932B2, pp. 1-32, 2020.
- [5] BECKER, N.D.: *Application of asynchronous coded multiple access (ACMA) in a system employing orthogonal frequency division multiplexing (OFDM)*, US-10819479B2, pp. 1-11, 2020.
- [6] LIN, Z., SIMA, J., BAI, B., CHEN, W., GUO, X.: *Electronic device and method for interleave division multiple access communication*, US-11128393B2, pp. 1-41, 2021.
- [7] LEE, H., LEE, S.: *Method and device for performing communication using orthogonal or nonorthogonal code multiple access scheme in wireless communication system*, US-11336343B2, pp. 1-82, 2022.
- [8] ZHANG, C., XIONG, Q., QIAN, C., YU, B., SUN, C.: *Apparatus and method for in multiple access in wireless communication*, US-11695507B2, pp. 1-110, 2023.
- [9] ELDESSOKI, S., DOMMEL, J., GORGANI, S.A., SHIN, W., HAUSTEIN, T., THIELE, L., KO, Y.-J., BAEK, S.: *Communicating data of a first user equipment and data of a second user equipment on shared resources of a wireless communication system*, US-20230262666A1, 2023.
- [10] DANG, J., CHU, W., LU, P.: *Electronic apparatus and method for wireless communication network control end and network node*, US-11777669B2, pp. 1-34, 2023.
- [11] KOBAYASHI, Y., TANAKA, K., FUKUDA, H., MURAYAMA, Y.: *Storage system, data write control method, and non-transitory computer readable medium for storing data write control program*, US-12045507B2, pp. 1-23, 2024.
- [12] KIMURA, R., TANG, Y.: *Apparatus for transmitting data in interleave division multiple access (IDMA) system*, US-12218690B2, pp. 1-60, 2025.
- [13] ELDESSOKI, S., DOMMEL, J., SHIN, W., HAUSTEIN, T., THIELE, L., KO, Y.-J., BAEK, S., YON, C.: *Joint transmissions of data in a wireless communication system using a non-orthogonal multiple access transmission scheme*, US-20250192933A1, pp. 1-30, 2025.

Review process

Single-blind peer review process.

